

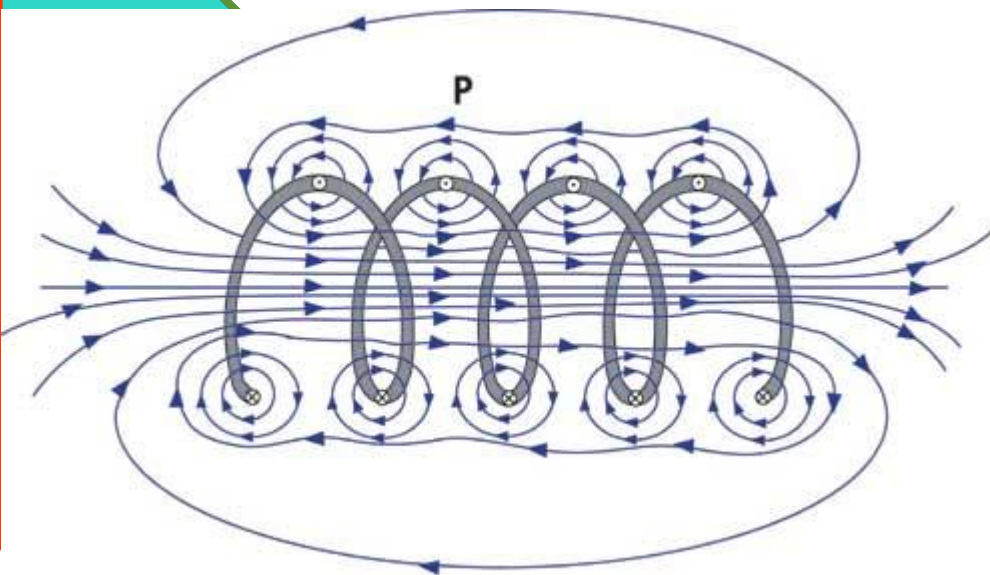

Chapter 30

Induction and Inductance



30 INDUCTION AND INDUCTANCE 791

- 30-1 What Is Physics? 791
- 30-2 Two Experiments 791
- 30-3 Faraday's Law of Induction 792
- 30-4 Lenz's Law 794
- 30-5 Induction and Energy Transfers 797
- 30-6 Induced Electric Fields 800
- 30-7 Inductors and Inductance 805
- 30-8 Self-Induction 806
- 30-9 *RL* Circuits 807
- 30-10 Energy Stored in a Magnetic Field 811
- 30-11 Energy Density of a Magnetic Field 812
- 30-12 Mutual Induction 813

First Experiment

• Figure shows a conducting loop connected to a sensitive meter. Because there is **no battery** or other source of emf included, there is **no current** in the circuit. However, if we move a **bar magnet** toward the loop, a **current suddenly appears** in the circuit.

• **A magnetic field can produce an electric field that can drive a current.** (*Faraday's law of induction*)

1. A current appears only if there is relative motion between the loop and the magnet; when the motion ceases the current disappears.

2. Faster motion produces a greater current.

3. If moving the magnet's north pole toward the loop causes, say, clockwise current, then moving the north pole away causes counterclockwise current.

• The current produced in the loop is called an **induced current.**

• The work done per unit charge to produce that current is called an **induced emf.**

• **The process of producing the current and emf is called induction.**

$$(\Delta \Phi) / \Delta t = \mathcal{E} = \text{emf}$$

The magnet's motion creates a current in the loop.

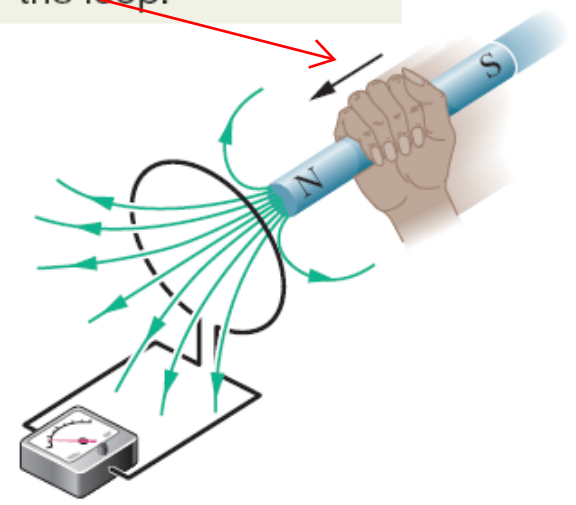

Fig. 30-1 An ammeter registers a current in the wire loop when the magnet is moving with respect to the loop.

Second Experiment

- For this experiment we use the apparatus of Fig 30-2, with the two conducting loops close to each other but not touching.
- If we **close** switch S, the meter **suddenly** and briefly registers a current -**an induced current**- in the left-hand loop.
- If we then **open** the switch, another **sudden** and brief **induced current** appears in the left hand loop, but in the **opposite direction**.

We get an induced current (and thus an induced emf) only when the current in the right-hand loop

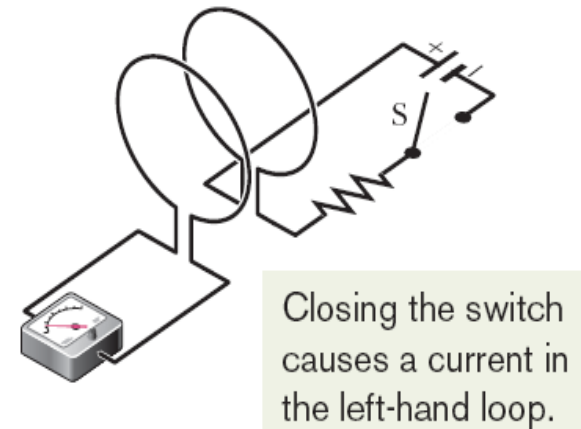

Fig. 30-2 An ammeter registers a current in the left-hand wire loop just as switch S is closed (to turn on the current in the right-hand wire loop) or opened (to turn off the current in the right-hand loop). No motion of the coils is involved.



An emf is induced in the loop at the left in Figs. 30-1 and 30-2 when the number of magnetic field lines that pass through the loop is changing.

- **Faraday's law of induction:** An emf is induced in a loop when the number of magnetic field lines that pass through the loop is changing.

Φ_B : magnetic flux

flux

area

The magnitude of the emf \mathcal{E} induced in a conducting loop is equal to the rate at which the magnetic flux Φ_B through that loop changes with time.

- To calculate the amount of magnetic field, we define a **magnetic flux** for a loop enclosing an area A which is placed in a magnetic field \mathbf{B} .

$$\Phi_B = \int \vec{B} \cdot d\vec{A} \quad (\text{magnetic flux through area } A)$$

$$\Phi_B = BA \quad (\vec{B} \perp \text{ area } A, \vec{B} \text{ uniform}).$$

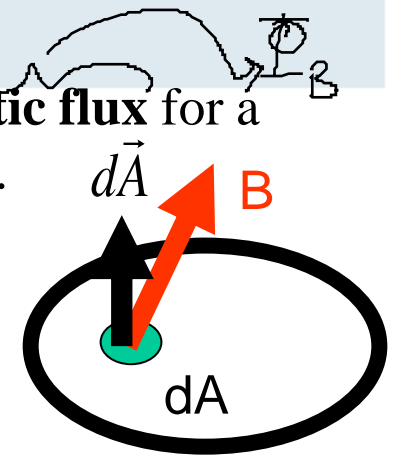

- The SI unit for magnetic flux is the tesla-square meter, which is called the **weber** (Wb).
- The magnitude of the emf \mathcal{E} induced in a conducting loop is equal to the rate at which the magnetic flux Φ_B through that loop changes with time.
- The magnetic flux through a coil of N turns;

$$1 \text{ weber} = 1 \text{ Wb} = 1 \text{ T} \cdot \text{m}^2$$

$$\mathcal{E} = - \frac{d\Phi_B}{dt} \quad (\text{Faraday's law})$$

why!?! (OPPOSE)

$$\mathcal{E} = -N \frac{d\Phi_B}{dt} \quad (\text{coil of } N \text{ turns})$$

$$\Phi_B = \int \vec{B} \cdot d\vec{A} \quad (\text{magnetic flux through area } A) \quad \mathcal{E} = -\frac{d\Phi_B}{dt} \quad (\text{Faraday's law})$$

General means by which we can change the magnetic flux through a coil:

1. Change the **magnitude B** of the magnetic field within the coil.
2. Change either the total **area** of the coil or the portion of that **area** that lies within the magnetic field (expanding the coil or sliding it into or out of the field).
3. Change the **angle** between the direction of the magnetic field B and the plane of the coil (for example, by rotating the coil so that field B is first perpendicular to the plane of the coil and then is along that plane).

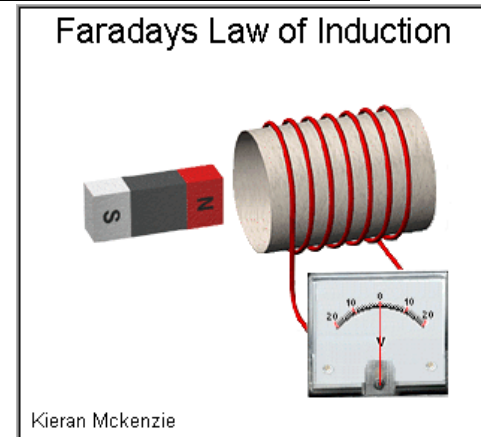

The induced emf tends to **oppose the flux change** and the **minus sign** indicates **this opposition**. **This minus sign is referred to as Lenz's Law.**

an increase $\rightarrow (-)$: decrease (oppose)
 a decrease $\rightarrow (+)$: increase (support)

Sample Problem

$$n = \# / \text{length}$$

Induced emf in coil due to a solenoid

The long solenoid S shown (in cross section) in Fig. 30-3 has 220 turns/cm and carries a current $i = 1.5$ A; its diameter D is 3.2 cm. At its center we place a 130-turn closely packed coil C of diameter $d = 2.1$ cm. The current in the solenoid is reduced to zero at a steady rate in 25 ms. What is the magnitude of the emf that is induced in coil C while the current in the solenoid is changing?

KEY IDEAS

1. Because it is located in the interior of the solenoid, coil C lies within the magnetic field produced by current i in the solenoid; thus, there is a magnetic flux Φ_B through coil C.
2. Because current i decreases, flux Φ_B also decreases.
3. As Φ_B decreases, emf \mathcal{E} is induced in coil C.

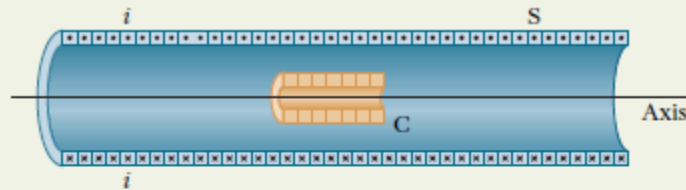

Fig. 30-3 A coil C is located inside a solenoid S, which carries current i .

4. The flux through each turn of coil C depends on the area A and orientation of that turn in the solenoid's magnetic field \vec{B} . Because \vec{B} is uniform and directed perpendicular to area A , the flux is given by Eq. 30-2 ($\Phi_B = BA$).
5. The magnitude B of the magnetic field in the interior of a solenoid depends on the solenoid's current i and its number n of turns per unit length, according to Eq. 29-23 ($B = \mu_0 in$).

Calculations: Because coil C consists of more than one turn, we apply Faraday's law in the form of Eq. 30-5 ($\mathcal{E} = -N d\Phi_B/dt$), where the number of turns N is 130 and $d\Phi_B/dt$ is the rate at which the flux changes.

Because the current in the solenoid decreases at a steady rate, flux Φ_B also decreases at a steady rate, and so we can write $d\Phi_B/dt$ as $\Delta\Phi_B/\Delta t$. Then, to evaluate $\Delta\Phi_B$, we need the final and initial flux values. The final flux $\Phi_{B,f}$ is zero because the final current in the solenoid is zero. To find the initial flux $\Phi_{B,i}$ we note that area A is $\frac{1}{4}\pi d^2$ ($= 3.464 \times 10^{-4} \text{ m}^2$) and the number n is 220 turns/cm, or 22 000 turns/m. Substituting Eq. 29-23 into Eq. 30-2 then leads to

$$\begin{aligned} \Phi_{B,i} &= BA = (\mu_0 in)A \\ &= (4\pi \times 10^{-7} \text{ T} \cdot \text{m/A})(1.5 \text{ A})(22\,000 \text{ turns/m}) \\ &\quad \times (3.464 \times 10^{-4} \text{ m}^2) \\ &= 1.44 \times 10^{-5} \text{ Wb}. \end{aligned}$$

Now we can write

$$\begin{aligned} \frac{d\Phi_B}{dt} &= \frac{\Delta\Phi_B}{\Delta t} = \frac{\Phi_{B,f} - \Phi_{B,i}}{\Delta t} \\ &= \frac{(0 - 1.44 \times 10^{-5} \text{ Wb})}{25 \times 10^{-3} \text{ s}} \\ &= -5.76 \times 10^{-4} \text{ Wb/s} = -5.76 \times 10^{-4} \text{ V}. \end{aligned}$$

We are interested only in magnitudes; so we ignore the minus signs here and in Eq. 30-5, writing

$$\begin{aligned} \mathcal{E} &= N \frac{d\Phi_B}{dt} = (130 \text{ turns})(5.76 \times 10^{-4} \text{ V}) \\ &= 7.5 \times 10^{-2} \text{ V} = \underline{\underline{75 \text{ mV}}}. \end{aligned} \quad \text{(Answer)}$$

$d \rightarrow 3.2 \text{ cm}$
 $\rightarrow 2.1 \text{ cm}$

$$\Phi_B = BA$$

$$\mathcal{E} = -N \frac{d\Phi_B}{dt}$$

$i = 0$
 $i = 1.5 \text{ A}$

Lenz's Law: An induced current has a direction such that the magnetic field due to this induced current opposes the change in the magnetic flux that induces the current.

Lenz's Law can be evaluated in two different ways;

1. Opposition to Pole Movement.
 - To *oppose* the magnetic flux increase being caused by the approaching magnet, the loop's north pole (and thus μ) must face *toward* the approaching north pole so as to repel it.
 - Then the curled-straight right-hand rule for μ tells us that the current induced in the loop must be counterclockwise in.

2. Opposition to Flux Change $\int \vec{v} \cdot \vec{l} (1, 2)$

- As the north pole of the magnet then nears the loop with its magnetic field \mathbf{B} directed *downward*, the flux through the loop increases.
- To oppose this increase in flux, the induced current i must set up its own field \mathbf{B}_{ind} directed *upward* inside the loop, as shown in Fig. 30-5a; then the upward flux of field opposes the increasing downward flux of field \mathbf{B} . The curled-straight right-hand rule tells us that i must be counterclockwise in Fig. 30-5a.

Note carefully that the flux of always opposes

The induced emf has the same direction as the induced current.

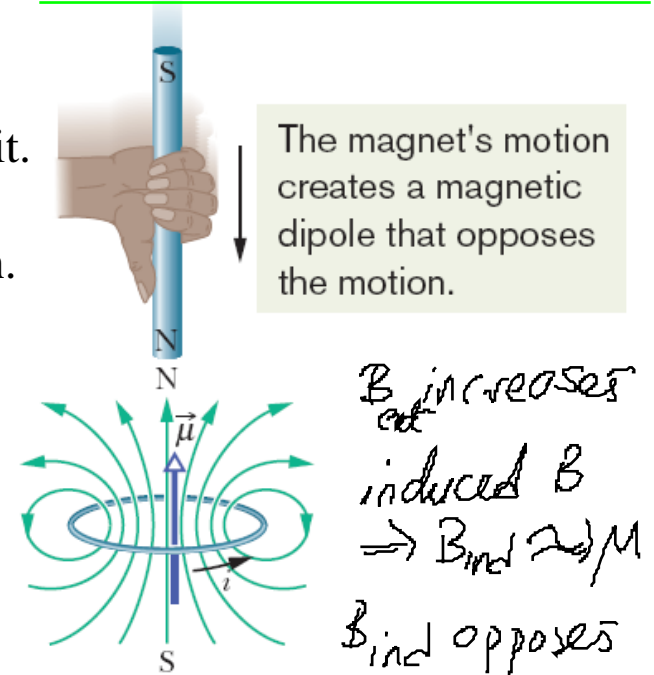

Fig. 30-4 Lenz's law at work. As the magnet is moved toward the loop, a current is induced in the loop. The current produces its own magnetic field, with magnetic dipole moment $\vec{\mu}$ oriented so as to oppose the motion of the magnet. Thus, the induced current must be counterclockwise as shown.

30-4 Lenz's Law

$B \rightarrow B_{\text{ind}}$
 $B_{\text{induced}}: B_{\text{ind}}$

Increasing the external field \vec{B} induces a current with a field \vec{B}_{ind} that opposes the change.

Decreasing the external field \vec{B} induces a current with a field \vec{B}_{ind} that opposes the change.

Increasing the external field \vec{B} induces a current with a field \vec{B}_{ind} that opposes the change.

Decreasing the external field \vec{B} induces a current with a field \vec{B}_{ind} that opposes the change.

The induced current creates this field, trying to offset the change.

The fingers are in the current's direction; the thumb is in the induced field's direction.

eliminate

B : downward support

B : upward

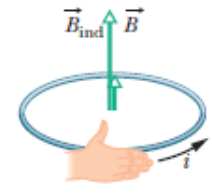
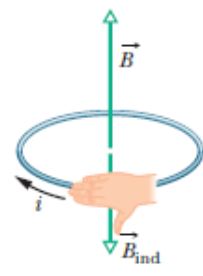
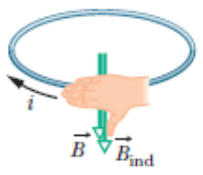
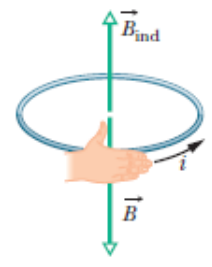
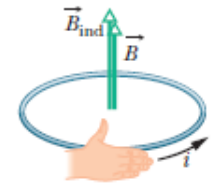
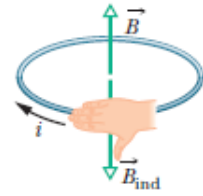
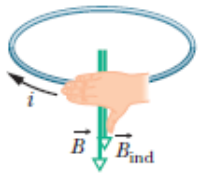
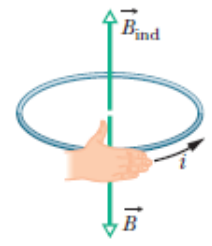
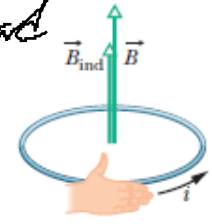
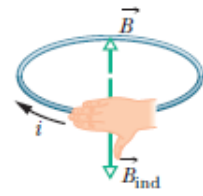
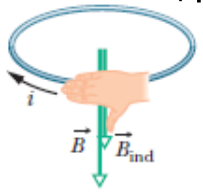
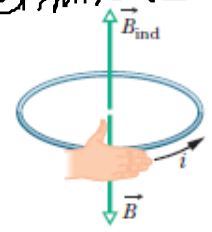

opposes the CHANGE!!

(a)

(b)

(c)

(d)

The direction of the current i induced in a loop is such that the current's magnetic field \vec{B}_{ind} opposes the change in the magnetic field \vec{B} inducing i . The field \vec{B}_{ind} is always directed opposite an increasing field \vec{B} (a, c) and in the same direction as a decreasing field \vec{B} (b, d). The curled – straight right-hand rule gives the direction of the induced current based on the direction of the induced field.

30-4 Lenz's Law

Example

A closed loop of wire encloses an area of $A = 1 \text{ m}^2$ in which in a uniform magnetic field exists at 30° to the PLANE of the loop. The magnetic field is **DECREASING** at a rate of $\frac{dB}{dt} = 1 \text{ T/s}$. The resistance of the wire is 10Ω .

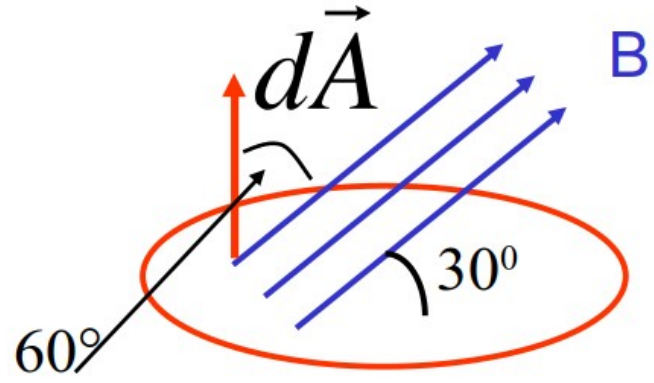

$$\Phi_B = \int \vec{B} \cdot d\vec{A}$$

$$= BA \cos(60^\circ) = BA/2$$

$$|E| = \frac{d\Phi_B}{dt} = \frac{A}{2} \frac{dB}{dt}$$

$$i = \frac{|E|}{R} = \frac{A}{2R} \frac{dB}{dt}$$

$$i = \frac{(1\text{m}^2)}{2(10\Omega)} (1\text{T/s}) = 0.05 \text{ A}$$

What is the induced current?

Is it
 ...clockwise or
 ...counterclockwise? ★

30-4 Lenz's Law

Example: The Generator

A square loop of wire of side L is rotated at a uniform frequency f in the presence of a uniform magnetic field B as shown.

Describe the EMF induced in the loop.

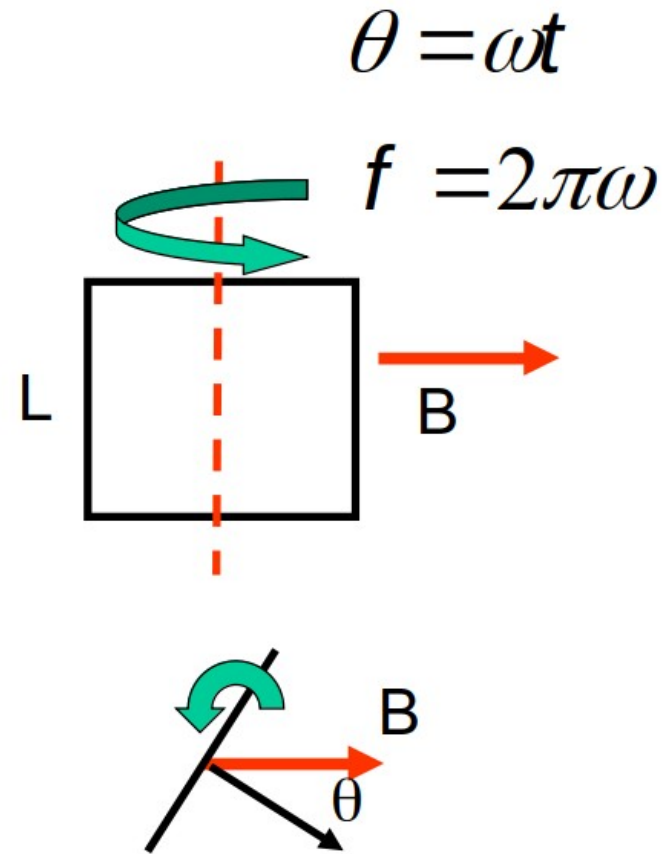

FYII

$$\Phi_B = \int_S \vec{B} \cdot d\vec{A}$$

$$= BL^2 \cos(\theta)$$

$$E = - \frac{d\Phi_B}{dt} = BL^2 \frac{d\theta}{dt} \sin(\theta) = BL^2 (2\pi f) \sin(2\pi ft)$$

Sample Problem

Induced emf and current due to a changing uniform B field

changing B

Figure 30-6 shows a conducting loop consisting of a half-circle of radius $r = 0.20$ m and three straight sections. The half-circle lies in a uniform magnetic field \vec{B} that is directed out of the page; the field magnitude is given by $B = 4.0t^2 + 2.0t + 3.0$, with B in teslas and t in seconds. An ideal battery with emf $\mathcal{E}_{\text{bat}} = 2.0$ V is connected to the loop. The resistance of the loop is 2.0Ω .

At $t = 10$ s, then,

$$\begin{aligned} \mathcal{E}_{\text{ind}} &= \frac{\pi (0.20 \text{ m})^2}{2} [8.0(10) + 2.0] \\ &= 5.152 \text{ V} \approx 5.2 \text{ V}. \end{aligned} \quad (\text{Answer})$$

(a) What are the magnitude and direction of the emf \mathcal{E}_{ind} induced around the loop by field \vec{B} at $t = 10$ s?

Direction: To find the direction of \mathcal{E}_{ind} , we first note that in Fig. 30-6 the flux through the loop is out of the page and increasing. Because the induced field B_{ind} (due to the induced current) must oppose that increase, it must be *into* the page. Using the curled-straight right-hand rule (Fig. 30-5c), we find that the induced current is clockwise around the loop, and thus so is the induced emf \mathcal{E}_{ind} .

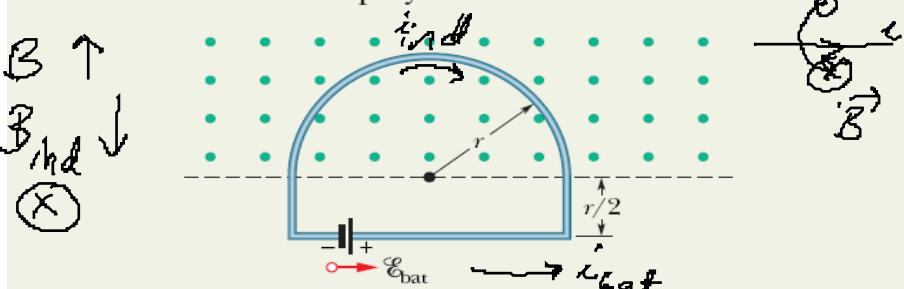

Fig. 30-6 A battery is connected to a conducting loop that includes a half-circle of radius r lying in a uniform magnetic field. The field is directed out of the page; its magnitude is changing.

(b) What is the current in the loop at $t = 10$ s?

Calculation: The induced emf \mathcal{E}_{ind} tends to drive a current clockwise around the loop; the battery's emf \mathcal{E}_{bat} tends to drive a current counterclockwise. Because \mathcal{E}_{ind} is greater than \mathcal{E}_{bat} , the net emf \mathcal{E}_{net} is clockwise, and thus so is the current. To find the current at $t = 10$ s, we use Eq. 27-2 ($i = \mathcal{E}/R$):

$$\mathcal{E}_{\text{ind}} = \frac{d\Phi_B}{dt} = \frac{d(BA)}{dt} = A \frac{dB}{dt}.$$

Because the flux penetrates the loop only within the half-circle, the area A in this equation is $\frac{1}{2}\pi r^2$. Substituting this and the given expression for B yields

$$\begin{aligned} i &= \frac{\mathcal{E}_{\text{net}}}{R} = \frac{\mathcal{E}_{\text{ind}} - \mathcal{E}_{\text{bat}}}{R} \\ &= \frac{5.152 \text{ V} - 2.0 \text{ V}}{2.0 \Omega} = 1.58 \text{ A} \approx 1.6 \text{ A}. \end{aligned} \quad (\text{Answer})$$

ind > E_bat

$$\begin{aligned} \mathcal{E}_{\text{ind}} &= A \frac{dB}{dt} = \frac{\pi r^2}{2} \frac{d}{dt} (4.0t^2 + 2.0t + 3.0) \\ &= \frac{\pi r^2}{2} (8.0t + 2.0). \end{aligned}$$

Sample Problem

Induced emf due to a changing nonuniform B field

changing B (non-uniform)

Figure 30-7 shows a rectangular loop of wire immersed in a nonuniform and varying magnetic field \vec{B} that is perpendicular to and directed into the page. The field's magnitude is given by $B = 4t^2x^2$, with B in teslas, t in seconds,

If the field varies with position, we must integrate to get the flux through the loop.

B is $B(x,t)$
non uniform

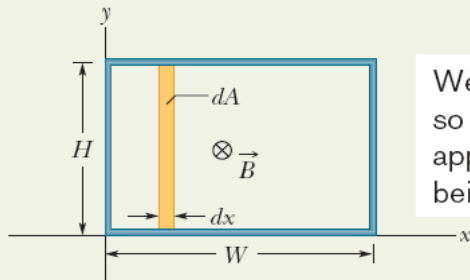

We start with a strip so thin that we can approximate the field as being uniform within it.

Fig. 30-7 A closed conducting loop, of width W and height H , lies in a nonuniform, varying magnetic field that points directly into the page. To apply Faraday's law, we use the vertical strip of height H , width dx , and area dA .

Calculations: In Fig. 30-7, \vec{B} is perpendicular to the plane of the loop (and hence parallel to the differential area vector $d\vec{A}$); so the dot product in Eq. 30-1 gives $B dA$. Because the magnetic field varies with the coordinate x but not with the coordinate y , we can take the differential area dA to be the area of a vertical strip of height H and width dx (as shown in Fig. 30-7). Then $dA = H dx$, and the flux through the loop is

$$\Phi_B = \int \vec{B} \cdot d\vec{A} = \int B dA = \int BH dx = \int 4t^2x^2H dx.$$

Treating t as a constant for this integration and inserting the integration limits $x = 0$ and $x = 3.0$ m, we obtain

$$\Phi_B = 4t^2H \int_0^{3.0} x^2 dx = 4t^2H \left[\frac{x^3}{3} \right]_0^{3.0} = 72t^2,$$

where we have substituted $H = 2.0$ m and Φ_B is in webers. Now we can use Faraday's law to find the magnitude of \mathcal{E} at any time t :

$$\mathcal{E} = \frac{d\Phi_B}{dt} = \frac{d(72t^2)}{dt} = 144t,$$

in which \mathcal{E} is in volts. At $t = 0.10$ s,

$$\mathcal{E} = (144 \text{ V/s})(0.10 \text{ s}) \approx \underline{\underline{14 \text{ V}}} \quad (\text{Answer})$$

The flux of \vec{B} through the loop is into the page in Fig. 30-7 and is increasing in magnitude because B is increasing in magnitude with time. By Lenz's law, the field B_{ind} of the induced current opposes this increase and so is directed out of the page. The curled-straight right-hand rule in Fig. 30-5a then tells us that the induced current is counterclockwise around the loop, and thus so is the induced emf \mathcal{E} .

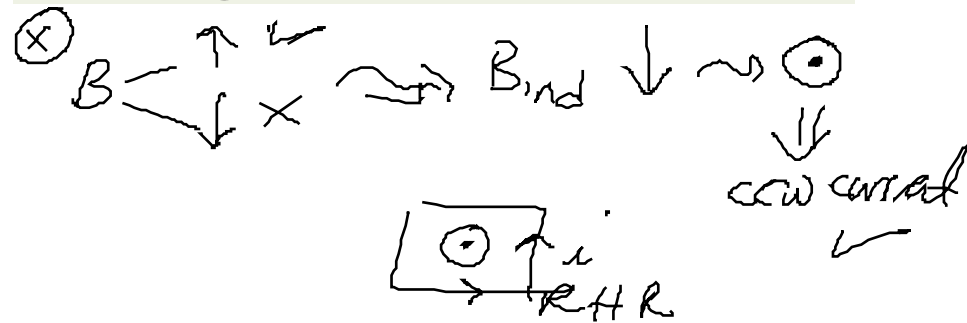

- If the loop is pulled at a constant velocity v , one must apply a constant force F to the loop since an equal and opposite magnetic force acts on the loop to oppose it.

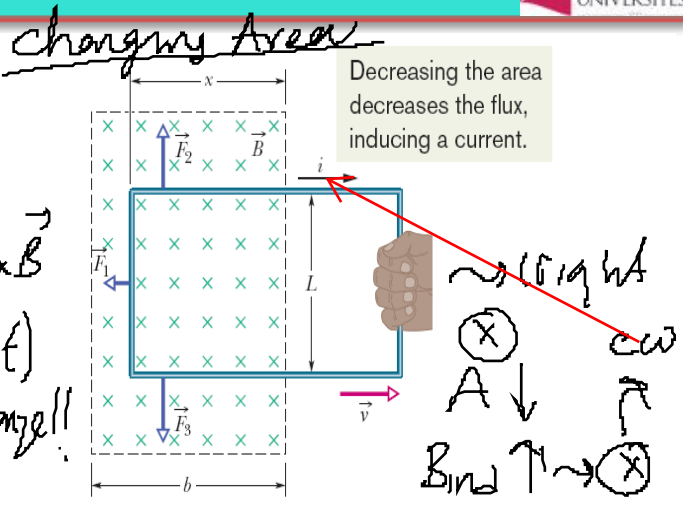

Fig. 30-8 You pull a closed conducting loop out of a magnetic field at constant velocity \vec{v} . While the loop is moving, a clockwise current i is induced in the loop, and the loop segments still within the magnetic field experience forces \vec{F}_1 , \vec{F}_2 , and \vec{F}_3 .

- Rate of Work:** The power is $P=Fv$.
- Flux change:** As the loop is pulled, the portion of its area within the magnetic field, and therefore the magnetic flux, decrease.

- According to Faraday's law, a current is produced in the loop. The magnitude of the flux through the loop is $\Phi_B = BA = BLx$.

- Induced emf:** Therefore,
$$\mathcal{E} = \frac{d\Phi_B}{dt} = \frac{d}{dt} BLx = BL \frac{dx}{dt} = BLv$$

- The induced current is therefore
$$i = \frac{BLv}{R}$$

- The net deflecting force is
$$F = F_1 = iLB \sin 90^\circ = iLB = \frac{B^2 L^2 v}{R}$$

- The power is therefore
$$P = Fv = \frac{B^2 L^2 v^2}{R}$$

L: constant
x: changing by time

- If we can apply the equation $i = \varepsilon / R$, this becomes
- Because three segments of the loop carry this current through the magnetic field, sideways deflecting forces act on those segments. $\vec{F}_d = i\vec{L} \times \vec{B}$
- These deflecting forces are \mathbf{F}_1 , \mathbf{F}_2 and \mathbf{F}_3 and from the symmetry, \mathbf{F}_2 and \mathbf{F}_3 forces cancel out remaining \mathbf{F}_1

$$i = \frac{BLv}{R}$$

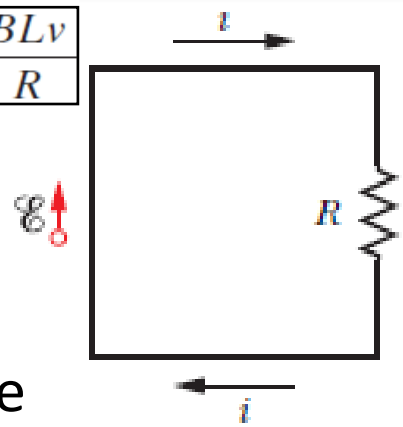

A circuit diagram for the loop while the loop is moving

$$F = F_1 = iLB \sin 90^\circ = iLB \longrightarrow F = \frac{B^2 L^2 v}{R}$$

The rate of doing

Thermal Energy

$$P = Fv = \frac{B^2 L^2 v^2}{R} \equiv P = \left(\frac{BLv}{R} \right)^2 R = \frac{B^2 L^2 v^2}{R}$$

Handwritten: $R \rightarrow P = i^2 R$

The work that you do in pulling the loop through the magnetic field **appears as thermal energy in the loop.**

30 Solved Problems

1. In Figure(a), a uniform magnetic field B increases in magnitude with time t as given by Figure(b), where the vertical axis scale is set by $B_s = 9.0 \text{ mT}$ and the horizontal axis is set by $t_s = 3.0 \text{ s}$. A circular conducting loop of area $8.0 \times 10^{-4} \text{ m}^2$ lies in the field, in the plane of the page. The amount of charge q passing point A on the loop is given in Fig. 30-40c as a function of t , with the vertical axis scale set by $q_s = 6.0 \text{ mC}$ and the horizontal axis scale again set by $t_s = 3.0 \text{ s}$. What is the loop's resistance? $R \approx \frac{V}{I}$

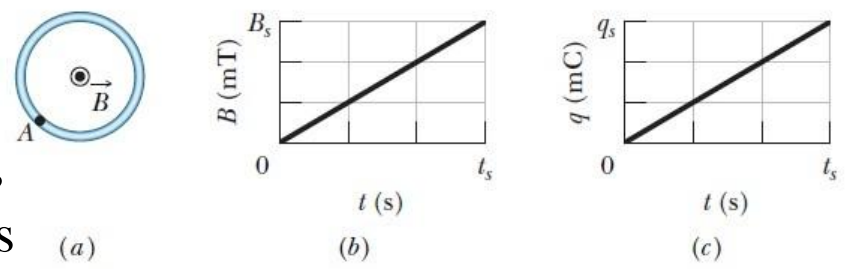

Fig. 30-40 Problem 14.

3(14)

- Increasing B with time.
- Area: $8 \times 10^{-4} \text{ m}^2$ (circular loop)

$\frac{\Delta B}{\Delta t} \approx \frac{\Delta q}{\Delta t}$ are given!
 $R = ?$

$\frac{\Delta B}{\Delta t} \rightarrow \frac{dB}{dt} : \text{slope} = \frac{9 \times 10^{-3} \text{ T}}{3 \text{ s}} = 3 \text{ mT/s}$

$\frac{dq}{dt} : \text{slope} = \frac{6 \times 10^{-3} \text{ C}}{3 \text{ s}} = 2 \times 10^{-3} \text{ A}$

Remember Faraday's Law: $\mathcal{E} = - \frac{d\Phi_B}{dt} = - A \frac{dB}{dt} = 2 \times 10^{-3} \text{ A}$

$\Rightarrow \mathcal{E} = -(8 \times 10^{-4} \text{ m}^2) 3 \times 10^{-3} \text{ T/s} : \text{induced emf at the loop}$

$\Rightarrow \text{Induced emf} \rightarrow \text{induced current at the loop}$

$R = \frac{V}{I} \rightarrow R = \frac{|\mathcal{E}|}{i} \sim \text{ignore minus sign} = \frac{(8 \times 10^{-4} \text{ m}^2) 3 \times 10^{-3} \text{ T/s}}{2 \times 10^{-3} \text{ A}} = \underline{\underline{0.0012 \Omega}}$

$B \uparrow \rightarrow B_{\text{ind}} \downarrow \rightarrow \text{cw current to oppose change}$

30 Solved Problems

2. A square wire loop with 2.00 m sides is perpendicular to a uniform magnetic field, with half the area of the loop in the field as shown in Figure. The loop contains an ideal battery with emf $\mathcal{E} = 20.0$ V. If the magnitude of the field varies with time according to $B = 0.0420 - 0.870t$, with B in teslas and t in seconds, what are (a) the net emf in the circuit and (b) the direction of the (net) current around the loop?

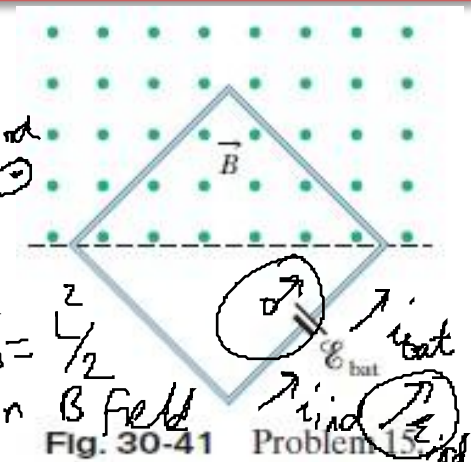

4(15)

$l = 2.00 \text{ m}$
 $R = 3 \Omega$
 $\mathcal{E}_B = 20.0 \text{ V}$
 $B = 0.0420 - 0.870t$
 $A = L^2/2$

i) $\mathcal{E}_i = - \frac{d\Phi_B}{dt} = - \frac{d(BA)}{dt} = - \frac{L^2}{2} \frac{dB}{dt} = - \frac{L^2}{2} \frac{d(0.0420 - 0.870t)}{dt}$
 $= - \frac{L^2}{2} (-0.870 \text{ T/s}) = \boxed{1.74 \text{ V}}$

B is out of page and decreasing \rightarrow induced emf should support the external magnetic field \Rightarrow ccw : direction of induced emf current.

\Rightarrow same direction with the battery $\rightarrow \mathcal{E}_{\text{total}} = \mathcal{E}_B + \mathcal{E}_i = 20.0 \text{ V} + 1.74 \text{ V} = \boxed{21.74 \text{ V}}$

ii) Current is in the ccw. $i = \frac{\mathcal{E}_{\text{total}}}{R} = \frac{21.74 \text{ V}}{3 \Omega} = 7.23 \text{ A}$

30 Solved Problems

3. In Fig. 30-53, a long rectangular conducting loop, of width L , resistance R , and mass m , is hung in a horizontal, uniform magnetic field \mathbf{B} that is directed into the page and that exists only above line aa . The loop is then dropped; during its fall, it accelerates until it reaches a certain terminal speed v_t . Ignoring air drag, find an expression for v_t .

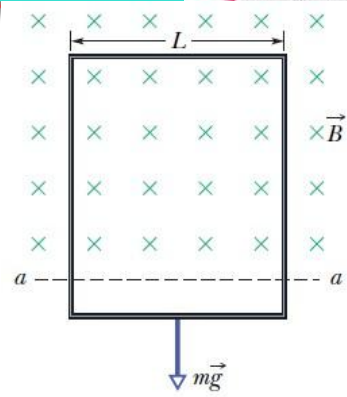

Fig. 30-53 Problem 34.

$F_{net} = 0$

7(34)

- long rectangular loop, width L
- Resistance R
- Mass m
- B (uniform) into page

first hung \rightarrow then dropped \rightarrow getting acceleration

\Rightarrow Flux changing (Area is changing) \Rightarrow induction (\mathcal{E})

\rightarrow Reaches a terminal speed $\Rightarrow F_{net} = 0$ (constant speed)

$F_{net} = 0 = i_{loop} L B - mg = 0$

$i_{loop} = \frac{mg}{LB} = \frac{|\mathcal{E}|}{R}$

$|\mathcal{E}| = B \frac{dA}{dt} = BLv_t$

$\Rightarrow \frac{mg}{LB} = \frac{B L v_t}{R} \Rightarrow v_t = \frac{mgR}{B^2 L^2}$

Support \rightarrow current \rightarrow end \downarrow Loop

Magnetic Flux

The magnetic flux through an area A in a magnetic field \mathbf{B} is defined as

$$\Phi_B = \int \vec{B} \cdot d\vec{A} \quad \text{Eq. 30-1}$$

If \mathbf{B} is perpendicular to the area and uniform over it, Eq. 30-1 becomes

$$\Phi_B = BA \quad (\vec{B} \perp A, \vec{B} \text{ uniform}). \quad \text{Eq. 30-2}$$

Faraday's Law of Induction

The induced *emf* is,

$$\mathcal{E} = - \frac{d\Phi_B}{dt} \quad \text{Eq. 30-4}$$

If the loop is replaced by a closely packed coil of N turns, the induced *emf* is

$$\mathcal{E} = -N \frac{d\Phi_B}{dt}. \quad \text{Eq. 30-5}$$

Lenz's Law

An induced current has a direction such that the magnetic field due to this induced current opposes the change in the magnetic flux that induces the current.

Emf and the Induced Magnetic Field

The induced *emf* is related to \mathbf{E} by

$$\mathcal{E} = \oint \vec{E} \cdot d\vec{s}, \quad \text{Eq. 30-19}$$

Faraday's law in its most general form,

$$\oint \vec{E} \cdot d\vec{s} = - \frac{d\Phi_B}{dt} \quad \text{Eq. 30-20}$$

Additional Materials

Eddy Currents

- Replace the conducting loop with a solid conducting plate.
- With the plate, however, the conduction electrons swirl about within the plate as if they were caught in an eddy (whirlpool) of water.
- Such a current is called an *eddy current*.
- The current induced in the plate results in mechanical energy being dissipated as thermal energy.
- An example; a conducting plate, free to rotate about a pivot, is allowed to swing down through a magnetic field like a pendulum.
- Each time the plate enters and leaves the field, a portion of its mechanical energy is transferred to its thermal energy.
- After several swings, no mechanical energy remains and the warmed-up plate just hangs from its pivot.

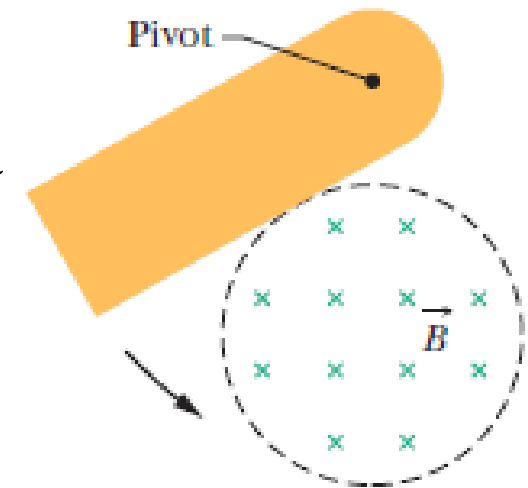
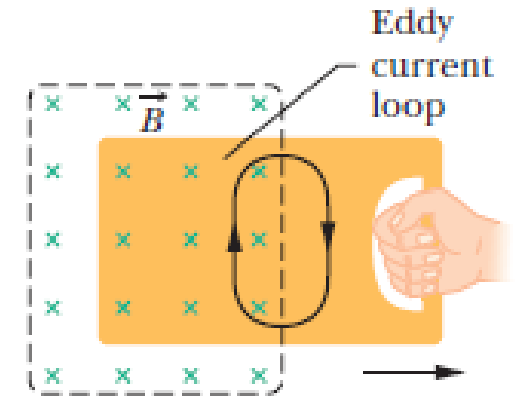

Start Your Engines: The Ignition Coil

The gap between the spark plug in a combustion engine needs an electric field of $\sim 10^7$ V/m in order to ignite the air-fuel mixture. For a typical spark plug gap, one needs to generate a potential difference $> 10^4$ V!

But, the typical EMF of a car battery is 12 V. So, how does a spark plug even work at all!?

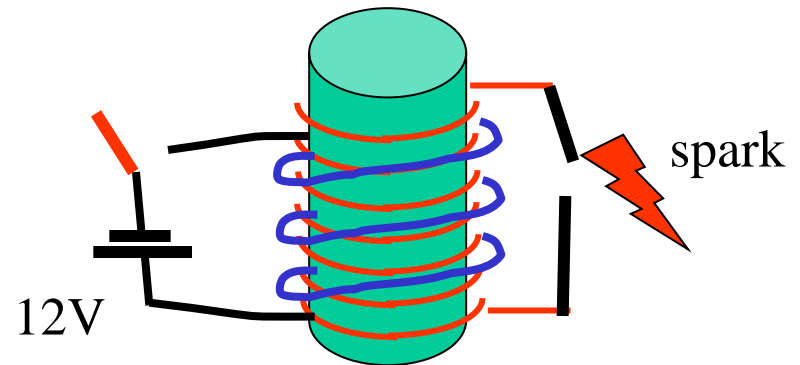

- Breaking the circuit changes the current through “primary coil”
- Result: LARGE change in flux thru secondary -- large induced EMF!

The “ignition coil” is a double layer solenoid:

- Primary: small number of turns -- 12 V
- Secondary: MANY turns -- spark plug

<http://www.familycar.com/Classroom/ignition.htm>

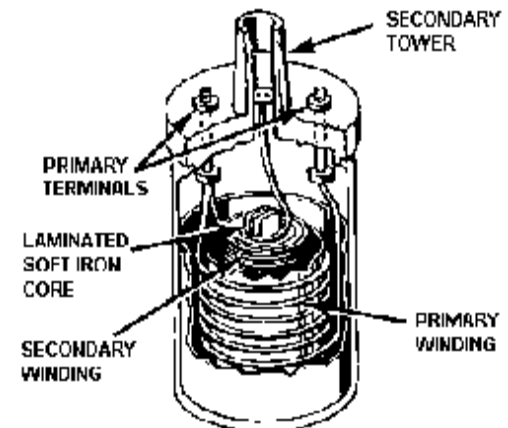



A changing magnetic field produces an electric field.

- Let us place a copper ring of radius r in a uniform external magnetic field and we increase the strength of this field at a steady rate.
- The magnetic flux through the ring will change at a steady rate an induced emf and thus an induced current will appear in the ring. (in the counterclockwise direction)
- The current in the copper ring produces an electric field. (**induced electric field**)
- **The electric field is induced even if there is no copper ring.**

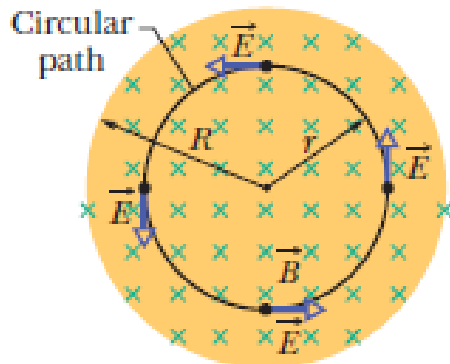
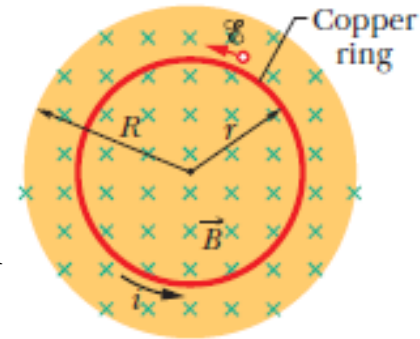

- The copper ring has been replaced by a hypothetical circular path of radius r .
- The electric field lines produced by the changing magnetic field must be a set of concentric circles.

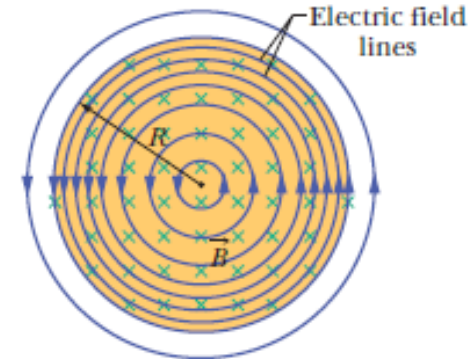

• As long as the magnetic field is increasing with time, the electric field will be present.

• If the magnetic field remains constant with time, there will be no induced electric field.

- Consider a particle of charge q_0 moving around the circular path. The work W done on it in one revolution by the induced electric field is $W = \mathcal{E}q_0$, where \mathcal{E} is the induced emf.

The work W done on it in one revolution

$$W = \int \vec{F} \cdot d\vec{s} = (q_0 E)(2\pi r) \xrightarrow{\text{more general expression}} W = \oint \vec{F} \cdot d\vec{s} = q_0 \oint \vec{E} \cdot d\vec{s}$$

- Here where $q_0 E$ is the magnitude of the force acting on the test charge and $2\pi r$ is the distance over which that force acts.

By using $\mathcal{E} = 2\pi r E$; $\mathcal{E} = \oint \vec{E} \cdot d\vec{s}$.

$$\oint \vec{E} \cdot d\vec{s} = - \frac{d\Phi_B}{dt} \quad (\text{Faraday's law})$$

- Combining this result with faradays law;
- Faraday's law can be applied to any closed path that can be drawn in a changing magnetic field.

Electric Potential: Induced electric fields are produced not by static charges but by a changing magnetic flux. Therefore,

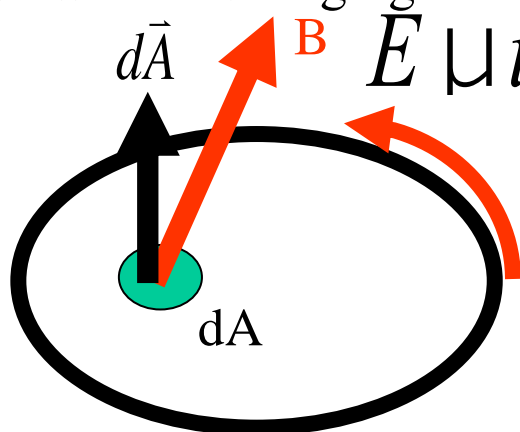

Electric potential has meaning only for electric fields that are produced by static charges; it has no meaning for electric fields that are produced by induction.

- Electric potential has meaning only for electric fields that are produced by static charges; it has no meaning for electric fields that are produced by induction.
- The field lines of induced electric fields form closed loops whereas field lines produced by static charges must start on positive charges and end on negative charges.

Sample Problem

Induced electric field due to changing B field, inside and outside

In Fig. 30-11*b*, take $R = 8.5$ cm and $dB/dt = 0.13$ T/s.

(a) Find an expression for the magnitude E of the induced electric field at points within the magnetic field, at radius r from the center of the magnetic field. Evaluate the expression for $r = 5.2$ cm.

KEY IDEA

An electric field is induced by the changing magnetic field, according to Faraday's law.

Calculations: To calculate the field magnitude E , we apply Faraday's law in the form of Eq. 30-20. We use a circular path of integration with radius $r \leq R$ because we want E for points within the magnetic field. We assume from the symmetry that \vec{E} in Fig. 30-11*b* is tangent to the circular path at all points. The path vector $d\vec{s}$ is also always tangent to the circular path; so the dot product $\vec{E} \cdot d\vec{s}$ in Eq. 30-20 must have the magnitude $E ds$ at all points on the path. We can also assume from the symmetry that E has the same value at all points along the circular path. Then the left side of Eq. 30-20 becomes

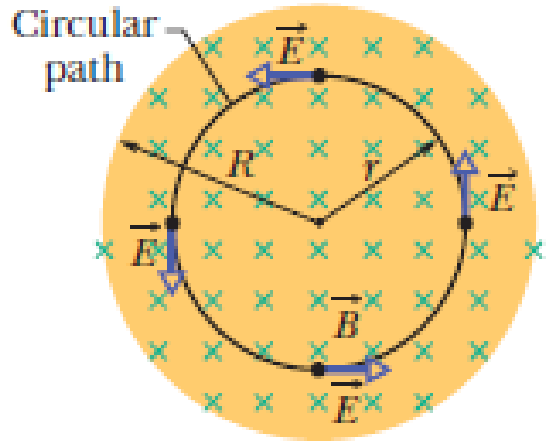

Fig. 30-11(b)

Sample Problem

Induced electric field due to changing B field, inside and outside

In Fig. 30-11*b*, take $R = 8.5$ cm and $dB/dt = 0.13$ T/s.

(a) Find an expression for the magnitude E of the induced electric field at points within the magnetic field, at radius r from the center of the magnetic field. Evaluate the expression for $r = 5.2$ cm.

Calculations: To calculate the field magnitude E , we apply Faraday's law in the form of Eq. 30-20. We use a circular path of integration with radius $r \leq R$ because we want E for points within the magnetic field. We assume from the symmetry that \vec{E} in Fig. 30-11*b* is tangent to the circular path at all points. The path vector $d\vec{s}$ is also always tangent to the circular path; so the dot product $\vec{E} \cdot d\vec{s}$ in Eq. 30-20 must have the magnitude $E ds$ at all points on the path. We can also assume from the symmetry that E has the same value at all points along the circular path. Then the left side of Eq. 30-20 becomes

$$\oint \vec{E} \cdot d\vec{s} = \oint E ds = E \oint ds = E(2\pi r). \quad (30-23)$$

(The integral $\oint ds$ is the circumference $2\pi r$ of the circular path.)

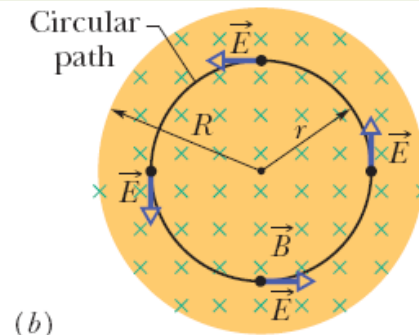

Fig. 30-11

$$\Phi_B = BA = B(\pi r^2). \quad (30-24)$$

Substituting this and Eq. 30-23 into Eq. 30-20 and dropping the minus sign, we find that

$$E(2\pi r) = (\pi r^2) \frac{dB}{dt}$$

$$\text{or} \quad E = \frac{r}{2} \frac{dB}{dt}. \quad (\text{Answer}) \quad (30-25)$$

Equation 30-25 gives the magnitude of the electric field at any point for which $r \leq R$ (that is, within the magnetic field). Substituting given values yields, for the magnitude of \vec{E} at $r = 5.2$ cm,

$$\begin{aligned} E &= \frac{(5.2 \times 10^{-2} \text{ m})}{2} (0.13 \text{ T/s}) \\ &= 0.0034 \text{ V/m} = 3.4 \text{ mV/m}. \quad (\text{Answer}) \end{aligned}$$

(b) Find an expression for the magnitude E of the induced electric field at points that are outside the magnetic field, at radius r from the center of the magnetic field. Evaluate the expression for $r = 12.5$ cm.

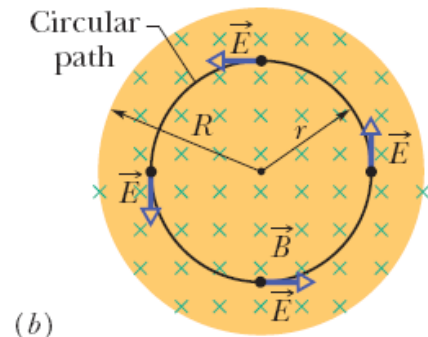

Fig. 30-11

(b)

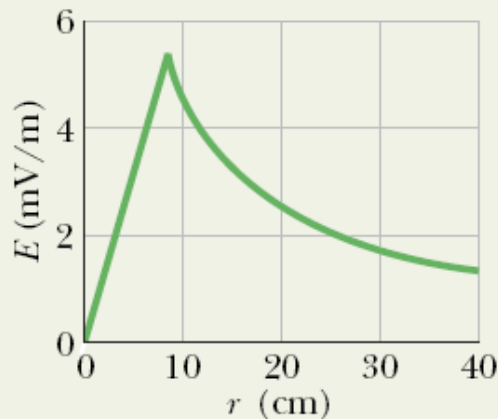

Fig. 30-12 A plot of the induced electric field $E(r)$.

Calculations: We can now write

$$\Phi_B = BA = B(\pi R^2). \quad (30-26)$$

Substituting this and Eq. 30-23 into Eq. 30-20 (without the minus sign) and solving for E yield

$$E = \frac{R^2}{2r} \frac{dB}{dt}. \quad (\text{Answer}) \quad (30-27)$$

Because E is not zero here, we know that an electric field is induced even at points that are outside the changing magnetic field, an important result that (as you will see in Section 31-11) makes transformers possible.

With the given data, Eq. 30-27 yields the magnitude of \vec{E} at $r = 12.5$ cm:

$$\begin{aligned} E &= \frac{(8.5 \times 10^{-2} \text{ m})^2}{(2)(12.5 \times 10^{-2} \text{ m})} (0.13 \text{ T/s}) \\ &= 3.8 \times 10^{-3} \text{ V/m} = 3.8 \text{ mV/m}. \quad (\text{Answer}) \end{aligned}$$

Equations 30-25 and 30-27 give the same result for $r = R$. Figure 30-12 shows a plot of $E(r)$. Note that the inside and outside plots meet at $r = R$.

Example

The figure shows two circular regions R_1 & R_2 with radii $r_1 = 1\text{m}$ & $r_2 = 2\text{m}$. In R_1 , the magnetic field B_1 points out of the page. In R_2 , the magnetic field B_2 points into the page.

Both fields are uniform and are **DECREASING** at the **SAME** steady rate = 1 T/s .

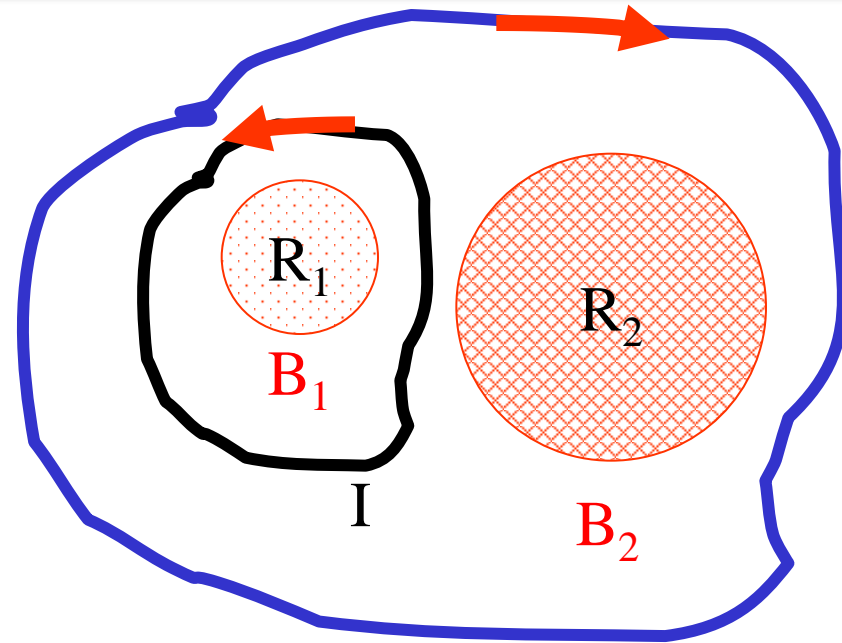

Calculate the “Faraday” integral for the two paths shown. $\oint_C \vec{E} \cdot d\vec{s}$ II

$$\text{Path I: } \oint_C \vec{E} \cdot d\vec{s} = -\frac{d\Phi_B}{dt} = -(\pi r_1^2)(-1\text{ T/s}) = +3.14\text{ V}$$

Path II:

$$\oint_C \vec{E} \cdot d\vec{s} = -\left[(\pi r_1^2)(-1\text{ T/s}) + (\pi r_2^2)(-1\text{ T/s}) \right] = +9.42\text{ V}$$

4. Figure shows a rod of length $L=10.0$ cm that is forced to move at constant speed $v= 5.00$ m/s along horizontal rails. The rod, rails, and connecting strip at the right form a conducting loop. The rod has resistance 0.400Ω ; the rest of the loop has negligible resistance. A current $i = 100$ A through the long straight wire at distance $a =10.0$ mm from the loop sets up a (nonuniform) magnetic field through the loop. Find the (a) emf and (b) current induced in the loop. (c) At what rate is thermal energy generated in the rod?

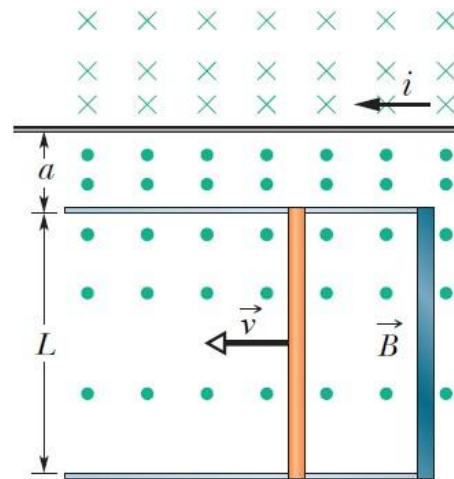

Fig. 30-52

6 (33)

Rod length
 $L = 10.0 \text{ cm}$

constant speed
 $v = 5.00 \text{ m/s}$

$R = 0.400 \text{ }\Omega$

wire (long, straight)

$i = 100 \text{ A}$

$d = 10.0 \text{ mm} = a$
 from the loop

i) induced emf $\equiv ?$ we need Φ_B created by wire.

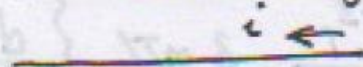

$B(2\pi r) = \mu_0 i$: Ampere's law $B(r) = \frac{\mu_0 i}{2\pi r}$: given as nonuniform B

$\Phi = AB \rightarrow d\Phi = B dA$

$d\Phi = \frac{\mu_0 i}{2\pi r} x dr$

$\Phi = \frac{\mu_0 i}{2\pi} \int_a^{a+L} \frac{dr}{r} = \frac{\mu_0 i}{2\pi} \ln\left(\frac{a+L}{a}\right)$

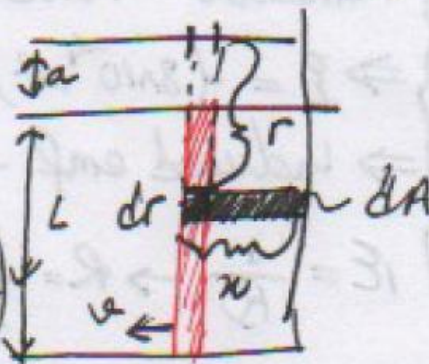

Now, apply Faraday's Law $\mathcal{E} = \frac{d\Phi_B}{dt} = \frac{\mu_0 i}{2\pi} \ln\left(\frac{a+L}{a}\right) \frac{dx}{dt}$

$\Rightarrow \mathcal{E} = \frac{(4\pi \times 10^{-7} \text{ Tm/A})(100 \text{ A})(5.00 \text{ m/s})}{2\pi} \ln\left(\frac{10^{-2} \text{ m} + 10^{-1} \text{ m}}{10^{-2} \text{ m}}\right) = 2.40 \times 10^{-4} \text{ V}$

ii) induced current $R = \frac{V}{i} \rightarrow i = \frac{\mathcal{E}}{R} = \frac{2.40 \times 10^{-4} \text{ V}}{0.400 \text{ }\Omega} = 6.00 \times 10^{-4} \text{ A}$ (loop)

iii) $P = i^2 R = (6.00 \times 10^{-4} \text{ A})^2 (0.400 \text{ }\Omega) = 1.44 \times 10^{-7} \text{ W}$ - dissipated thermal energy

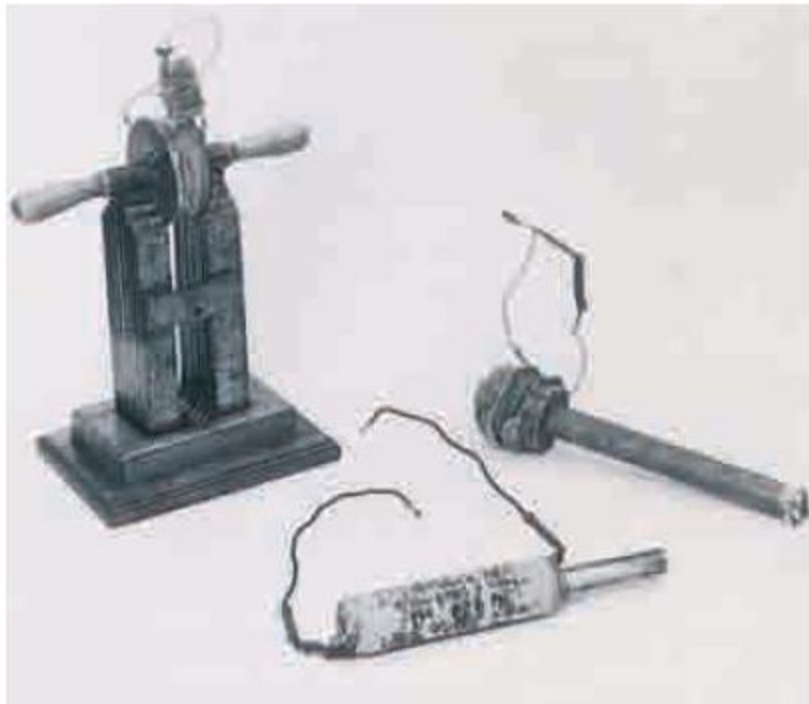

The crude inductors with which Michael Faraday discovered the law of induction. In those days amenities such as insulated wire were not commercially available. It is said that Faraday insulated his wires by wrapping them with strips cut from one of his wife's petticoats. (*The Royal Institution/Bridgeman Art Library/NY*)

- An **inductor** (symbol Ⓛ) can be used to produce a desired magnetic field.
- If we establish a **current** i in the windings (turns) of the solenoid which can be treated as our inductor, the current produces a **magnetic flux** Φ_B through the central region of the inductor.

- The inductance of the inductor is then

$$L = \frac{N\Phi_B}{i} \quad (\text{inductance defined})$$

- The SI unit of inductance is the tesla–square meter per ampere ($\text{T m}^2/\text{A}$). We call this the henry (H), after American physicist Joseph Henry.
- *Inductors are with respect to the magnetic field what capacitors are with respect to the electric field.*
- They “pack a lot of field in a small region”.
- Also, the higher the current, the higher the magnetic field they produce.

- What is the inductance per unit length near its middle?
- Consider a long solenoid of cross-sectional area A , with number of turns N , and of length l . The flux is $N\Phi_B = (nl)(BA)$.
- The magnitude of B is given by: $B = \mu_0 in$, (n is the number of turns per unit length)
- Therefore,
$$L = \frac{N\Phi_B}{i} = \frac{(nl)(BA)}{i} = \frac{(nl)(\mu_0 in)(A)}{i}$$

$$= \mu_0 n^2 l A.$$

Capacitance C how much potential for a given charge: $Q=CV$

The inductance per unit length near the center is therefore:

$$\frac{L}{l} = \mu_0 n^2 A \quad (\text{solenoid}).$$

Here,
$$\begin{aligned} \mu_0 &= 4\pi \times 10^{-7} \text{ T}\cdot\text{m/A} \\ &= 4\pi \times 10^{-7} \text{ H/m}. \end{aligned}$$

Inductance L how much magnetic flux for a given current: $\Phi=Li$

- Inductance depends only on the geometry of the device.
- If the solenoid is very much longer than its radius, the spreading of the magnetic field lines near the ends of the solenoid is neglected

- If two coils are near each other, a current i in one coil produces a magnetic flux Φ_B through second coil.
 - If we change this flux by changing the current, an induced emf appears in the second coil according to Faraday's Law.



An induced emf \mathcal{E}_L appears in any coil in which the current is changing.

- This process is called **self-induction**, and the emf that appears is called a **self-induced emf**.

Using $\mathcal{E}_L = -\frac{d(N\Phi_B)}{dt}$ and $N\Phi_B = Li$.

$$\mathcal{E}_L = -L \frac{di}{dt} \quad (\text{self-induced emf})$$

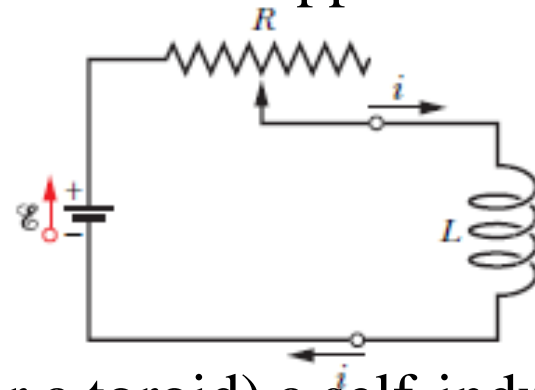

- In any inductor (such as a coil, a solenoid, or a toroid) a self-induced emf appears whenever the current changes with time.
- The magnitude of the current has no influence on the magnitude of the induced emf; only the rate of change of the current counts.
- The direction of a self-induced emf: (from Lenz's law) it has the orientation such that it opposes the change in current i .

The changing current changes the flux, which creates an emf that opposes the change.

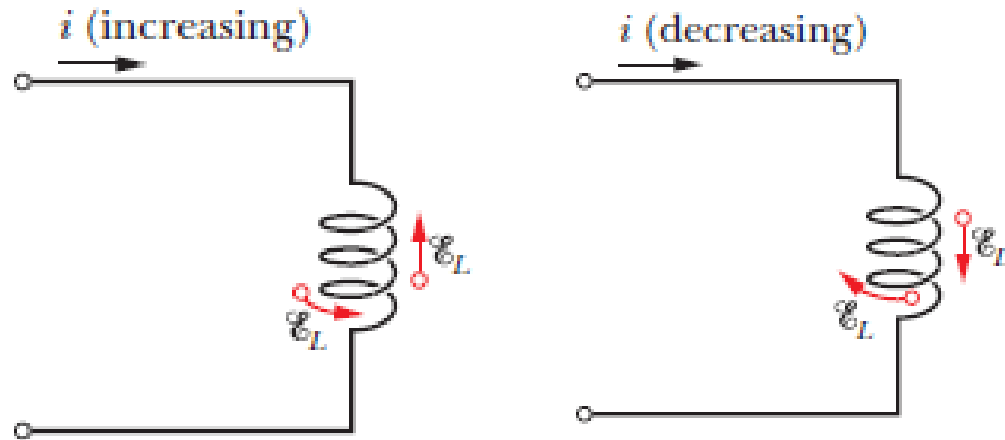

- We cannot define an electric potential within the inductor itself however, potentials at other points of the circuit can still be defined.
- We can define a self-induced potential difference V_L between the terminals of an inductor.
- For an ideal inductor, the magnitude of V_L is equal to the magnitude of the self-induced emf \mathcal{E}_L
- If the inductor has resistance r , the potential difference across the terminals of a real inductor then differs from the emf.

- If the inductor were not present, the current would rise rapidly to a steady state value ε/R .
- Because of the inductor, a self induced emf ε_L appears in the circuit.
- This emf opposes the rise of the current, by opposing the battery emf ε in polarity.
- Thus, the current in the resistor responds to the difference between two emfs; a constant ε due to the battery and a variable $\varepsilon_L (= -Ldi/dt)$ due to self-induction.
- As long as ε_L is present, the current will be less than ε/R .
- As time goes on, the rate at which the current increases becomes less rapid and the magnitude of the self-induced emf becomes smaller.

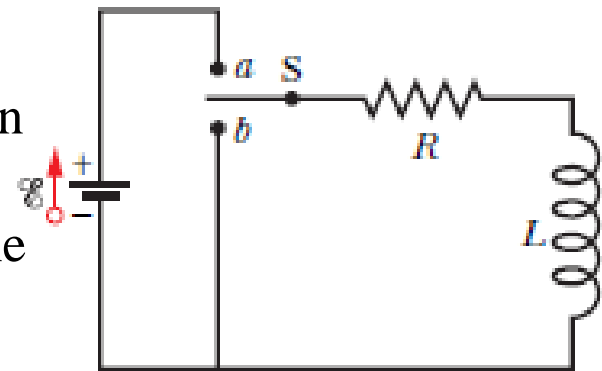

With the switch S thrown to *a*,

$$-iR - L \frac{di}{dt} + \varepsilon = 0$$

$$L \frac{di}{dt} + Ri = \varepsilon \quad (RL \text{ circuit})$$



Initially, an inductor acts to oppose changes in the current through it. A long time later, it acts like ordinary connecting wire.

$$i = \frac{\varepsilon}{R} (1 - e^{-Rt/L}) \quad \text{or}$$

$$i = \frac{\varepsilon}{R} (1 - e^{-t/\tau_L}) \quad (\text{rise of current})$$

$$\tau_L = \frac{L}{R} \quad (\text{time constant})$$

- The potential differences V_R (iR) across the resistor and inductor are;

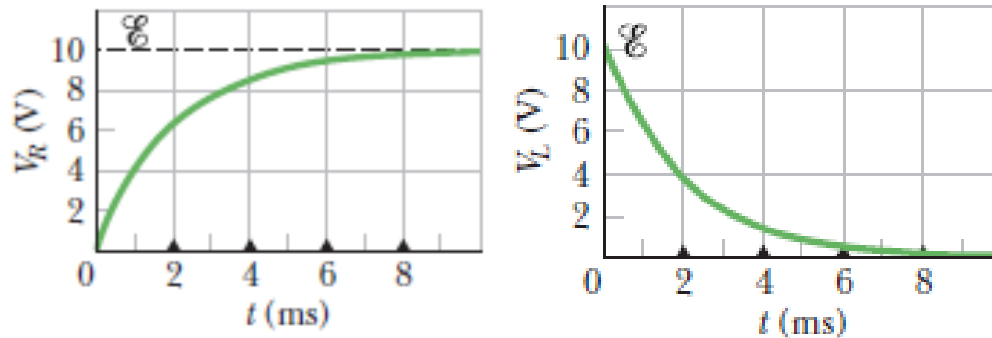

Fig. 30-17 The variation with time of (a) V_R , the potential difference across the resistor in the circuit of Fig. 30-16, and (b) V_L , the potential difference across the inductor in that circuit. The small triangles represent successive intervals of one inductive time constant $\tau_L = L/R$. The figure is plotted for $R = 2000 \Omega$, $L = 4.0 \text{ H}$, and $\mathcal{E} = 10 \text{ V}$.

The physical significance of the

time constant; $i = \frac{\mathcal{E}}{R} (1 - e^{-1}) = 0.63 \frac{\mathcal{E}}{R}$

- The time constant τ_L is the time it takes the current in the circuit to reach about 63% of its equilibrium value \mathcal{E}/R .
- If we suddenly remove the emf (i.e., switch is closed) from this same circuit, the charge does not immediately fall to zero but approaches zero in an exponential fashion:

$$L \frac{di}{dt} + iR = 0. \quad \longrightarrow \quad i = \frac{\mathcal{E}}{R} e^{-t/\tau_L} = i_0 e^{-t/\tau_L} \quad (\text{decay of current}).$$

Sample Problem

RL circuit, immediately after switching and after a long time

Figure 30-18*a* shows a circuit that contains three identical resistors with resistance $R = 9.0 \Omega$, two identical inductors with inductance $L = 2.0 \text{ mH}$, and an ideal battery with emf $\mathcal{E} = 18 \text{ V}$.

(a) What is the current i through the battery just after the switch is closed?

KEY IDEA

Just after the switch is closed, the inductor acts to oppose a change in the current through it.

Calculations: Because the current through each inductor is zero before the switch is closed, it will also be zero just afterward. Thus, immediately after the switch is closed, the inductors act as broken wires, as indicated in Fig. 30-18*b*. We then have a single-loop circuit for which the loop rule gives us

$$\mathcal{E} - iR = 0.$$

Substituting given data, we find that

$$i = \frac{\mathcal{E}}{R} = \frac{18 \text{ V}}{9.0 \Omega} = 2.0 \text{ A.} \quad (\text{Answer})$$

(b) What is the current i through the battery long after the switch has been closed?

KEY IDEA

Long after the switch has been closed, the currents in the circuit have reached their equilibrium values, and the inductors act as simple connecting wires, as indicated in Fig. 30-18*c*.

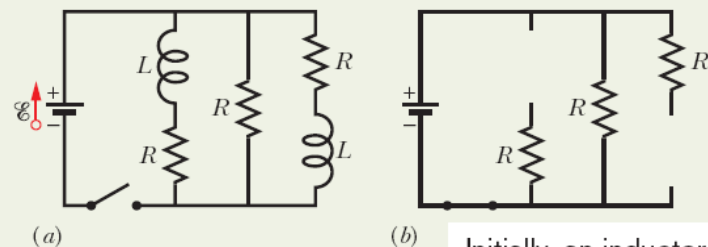

Initially, an inductor acts like broken wire.

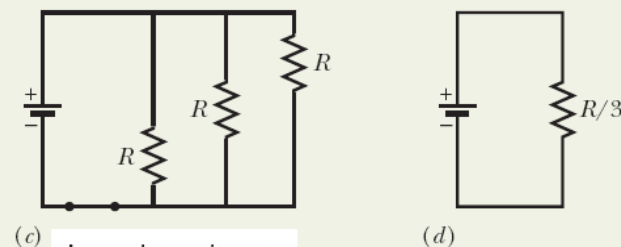

Long later, it acts like ordinary wire.

Fig. 30-18 (a) A multiloop RL circuit with an open switch. (b) The equivalent circuit just after the switch has been closed. (c) The equivalent circuit a long time later. (d) The single-loop circuit that is equivalent to circuit (c).

Calculations: We now have a circuit with three identical resistors in parallel; from Eq. 27-23, their equivalent resistance is $R_{\text{eq}} = R/3 = (9.0 \Omega)/3 = 3.0 \Omega$. The equivalent circuit shown in Fig. 30-18*d* then yields the loop equation $\mathcal{E} - iR_{\text{eq}} = 0$, or

$$i = \frac{\mathcal{E}}{R_{\text{eq}}} = \frac{18 \text{ V}}{3.0 \Omega} = 6.0 \text{ A.} \quad (\text{Answer})$$

Sample Problem

RL circuit, current during the transition

A solenoid has an inductance of 53 mH and a resistance of 0.37Ω . If the solenoid is connected to a battery, how long will the current take to reach half its final equilibrium value? (This is a *real solenoid* because we are considering its small, but nonzero, internal resistance.)

KEY IDEA

We can mentally separate the solenoid into a resistance and an inductance that are wired in series with a battery, as in Fig. 30-16. Then application of the loop rule leads to Eq. 30-39, which has the solution of Eq. 30-41 for the current i in the circuit.

Calculations: According to that solution, current i increases exponentially from zero to its final equilibrium value of \mathcal{E}/R . Let t_0 be the time that current i takes to reach half its equilibrium value. Then Eq. 30-41 gives us

$$\frac{1}{2} \frac{\mathcal{E}}{R} = \frac{\mathcal{E}}{R} (1 - e^{-t_0/\tau_L}).$$

We solve for t_0 by canceling \mathcal{E}/R , isolating the exponential, and taking the natural logarithm of each side. We find

$$\begin{aligned} t_0 &= \tau_L \ln 2 = \frac{L}{R} \ln 2 = \frac{53 \times 10^{-3} \text{ H}}{0.37 \Omega} \ln 2 \\ &= 0.10 \text{ s.} \end{aligned} \quad \text{(Answer)}$$

RC vs RL Circuits

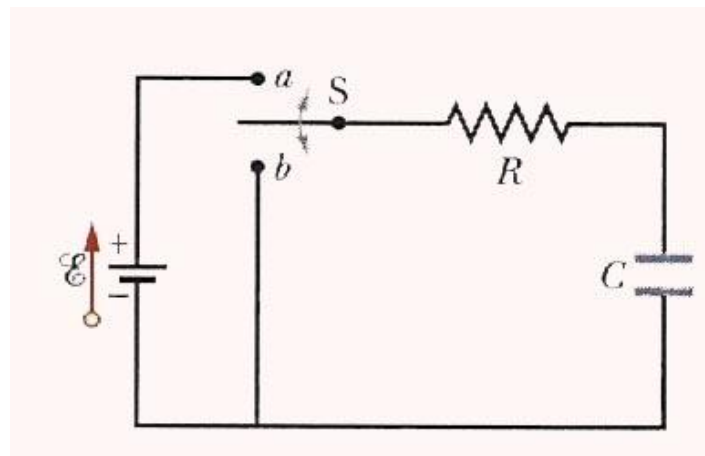

In an RC circuit, while charging,
 $Q = CV$ and the loop rule mean:

- charge increases from 0 to $C\mathcal{E}$
- current decreases from \mathcal{E}/R to 0
- voltage across capacitor increases from 0 to \mathcal{E}

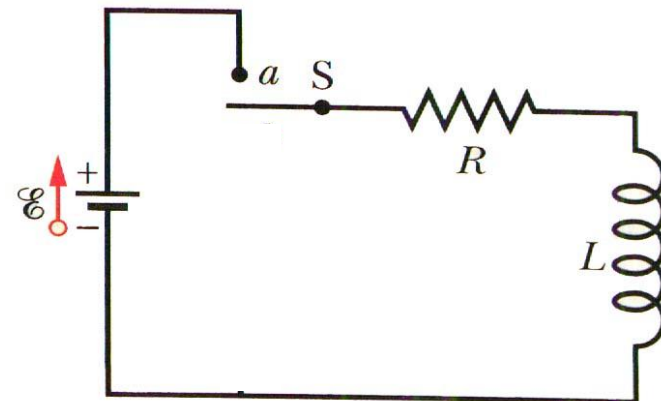

In an RL circuit, while fluxing up
 (rising current), $\mathcal{E} = Ldi/dt$ and the
 loop rule mean:

- magnetic field increases from 0 to B
- current increases from 0 to \mathcal{E}/R
- voltage across inductor decreases from $-\mathcal{E}$ to 0

- Magnetic energy is stored in a magnetic field with current instead of electric charges.

For the single loop circuit,

$$\mathcal{E} = L \frac{di}{dt} + iR$$

Multiply each side by i ,

$$\mathcal{E}i = Li \frac{di}{dt} + i^2R$$

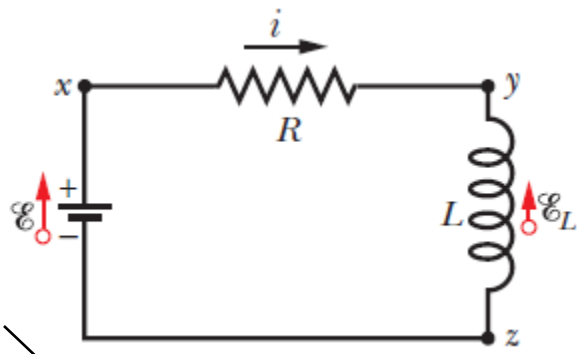

Recall that

Capacitors store energy in an **electric** field

Inductors store energy in a **magnetic** field.

the work done by the battery on charges

Energy stored in the magnetic field of the inductor

energy appears as thermal energy in the resistor

This represents the total energy stored by an inductor L carrying a current i .

$$U_B = \frac{1}{2} Li^2 \quad (\text{magnetic energy})$$

The rate dU_B/dt at which magnetic potential energy U_B is stored in the magnetic field.

$$\frac{dU_B}{dt} = Li \frac{di}{dt} \rightarrow \int_0^{U_B} dU_B = \int_0^i Li \, di$$

Sample Problem

Energy stored in a magnetic field

A coil has an inductance of 53 mH and a resistance of 0.35Ω .

(a) If a 12 V emf is applied across the coil, how much energy is stored in the magnetic field after the current has built up to its equilibrium value?

KEY IDEA

The energy stored in the magnetic field of a coil at any time depends on the current through the coil at that time, according to Eq. 30-49 ($U_B = \frac{1}{2} Li^2$).

Calculations: Thus, to find the energy $U_{B\infty}$ stored at equilibrium, we must first find the equilibrium current. From Eq. 30-41, the equilibrium current is

$$i_{\infty} = \frac{\mathcal{E}}{R} = \frac{12 \text{ V}}{0.35 \Omega} = 34.3 \text{ A.} \quad (30-51)$$

Then substitution yields

$$\begin{aligned} U_{B\infty} &= \frac{1}{2} Li_{\infty}^2 = \left(\frac{1}{2}\right)(53 \times 10^{-3} \text{ H})(34.3 \text{ A})^2 \\ &= 31 \text{ J.} \end{aligned} \quad (\text{Answer})$$

(b) After how many time constants will half this equilibrium energy be stored in the magnetic field?

Calculations: Now we are being asked: At what time t will the relation

$$U_B = \frac{1}{2} U_{B\infty}$$

be satisfied? Using Eq. 30-49 twice allows us to rewrite this energy condition as

$$\frac{1}{2} Li^2 = \left(\frac{1}{2}\right)\frac{1}{2} Li_{\infty}^2$$

$$\text{or} \quad i = \left(\frac{1}{\sqrt{2}}\right) i_{\infty} \quad (30-52)$$

This equation tells us that, as the current increases from its initial value of 0 to its final value of i_{∞} , the magnetic field will have half its final stored energy when the current has increased to this value. In general, we know that i is given by Eq. 30-41, and here i_{∞} (see Eq. 30-51) is \mathcal{E}/R ; so Eq. 30-52 becomes

$$\frac{\mathcal{E}}{R} (1 - e^{-t/\tau_L}) = \frac{\mathcal{E}}{\sqrt{2}R}.$$

By canceling \mathcal{E}/R and rearranging, we can write this as

$$e^{-t/\tau_L} = 1 - \frac{1}{\sqrt{2}} = 0.293,$$

which yields

$$\frac{t}{\tau_L} = -\ln 0.293 = 1.23$$

$$\text{or} \quad t \approx 1.2\tau_L. \quad (\text{Answer})$$

Thus, the energy stored in the magnetic field of the coil by the current will reach half its equilibrium value 1.2 time constants after the emf is applied.

- Consider a length l near the middle of a long solenoid of cross-sectional area A carrying current i ; the volume associated with this length is Al .
- The energy U_B stored by the length l of the solenoid must lie entirely within this volume because the magnetic field outside such a solenoid is approximately zero. Also, the stored energy must be uniformly distributed within the solenoid because the magnetic field is (approximately) uniform everywhere inside.
- Thus, the energy stored per unit volume of the field is $u_B = \frac{U_B}{Al}$

Since $U_B = \frac{1}{2}Li^2$;
$$u_B = \frac{Li^2}{2Al} = \frac{L}{l} \frac{i^2}{2A}$$

$$\frac{L}{l} = \mu_0 n^2 A \quad (\text{solenoid}). \quad (30-31)$$

$$u_B = \frac{B^2}{2\mu_0} \quad (\text{magnetic energy density})$$

$$u_E = \frac{e_0 E^2}{2}$$

- If two coils are close together, a steady current i in one coil will set up a magnetic flux Φ through the other coil.
- If we change i with time, an emf ε appears in the second coil (called as induction)
- To suggest the mutual interaction of the two coils and to distinguish it from self-induction, it is called **mutual induction**.

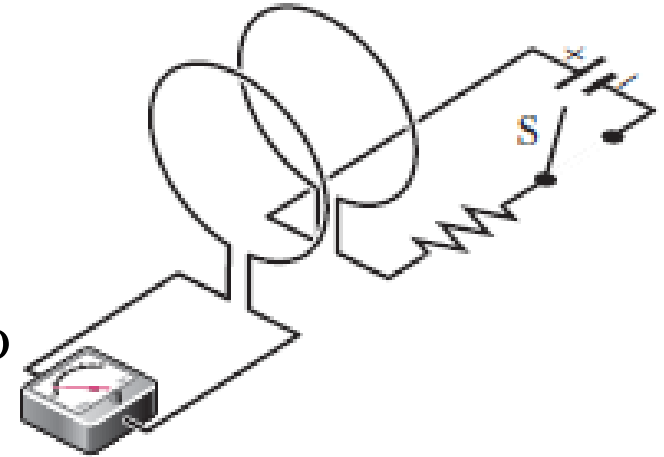

We define the mutual inductance M_{21} of coil 2 with respect to coil 1 as

$$M_{21} = \frac{N_2 \Phi_{21}}{i_1},$$

- We can recast the formula as;

$$M_{21}i_1 = N_2\Phi_{21}$$

$$\Rightarrow M_{21} \frac{di_1}{dt} = N_2 \frac{d\Phi_{21}}{dt}$$

The right side of this equation is, according to Faraday's law, just the magnitude of the emf \mathcal{E}_2 appearing in coil 2 due to the changing current in coil 1

$$\Rightarrow \mathcal{E}_2 = -M_{21} \frac{di_1}{dt}$$

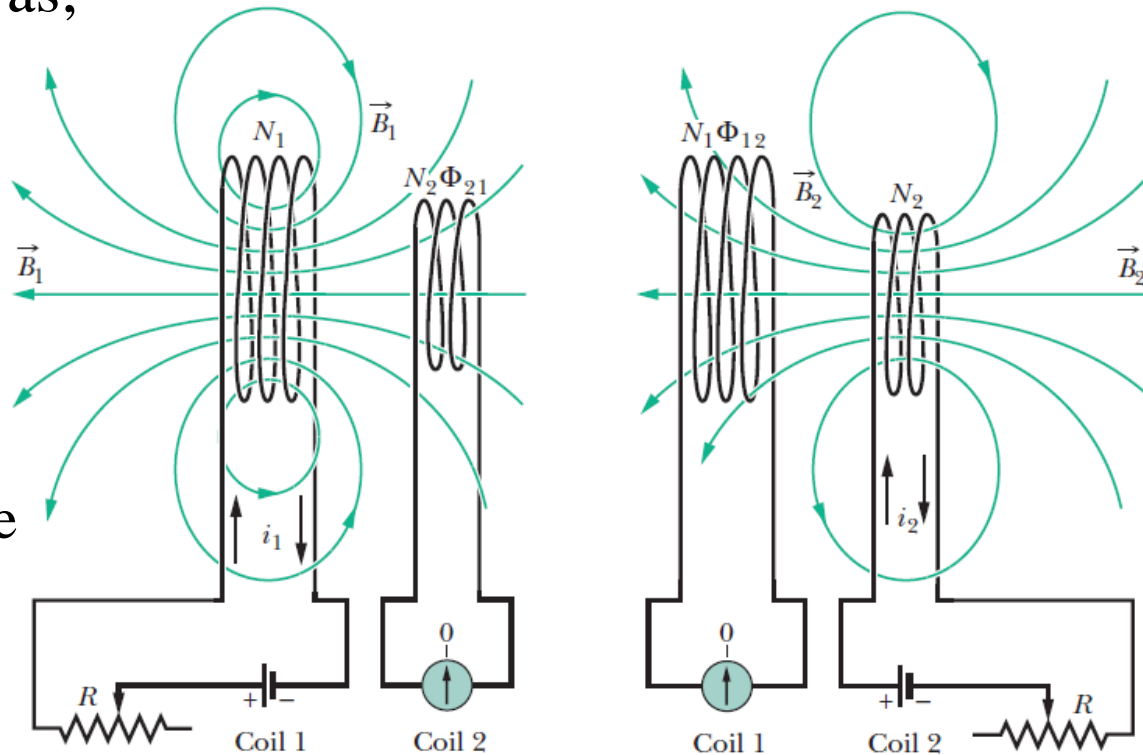

Here, minus sign indicates the *direction*

Since the proportionality constants M_{21} and M_{12} are the same,

$$\mathcal{E}_2 = -M \frac{di_1}{dt}$$

and

$$\mathcal{E}_1 = -M \frac{di_2}{dt}$$

Sample Problem

Mutual inductance of two parallel coils

Figure 30-20 shows two circular close-packed coils, the smaller (radius R_2 , with N_2 turns) being coaxial with the larger (radius R_1 , with N_1 turns) and in the same plane.

(a) Derive an expression for the mutual inductance M for this arrangement of these two coils, assuming that $R_1 \gg R_2$.

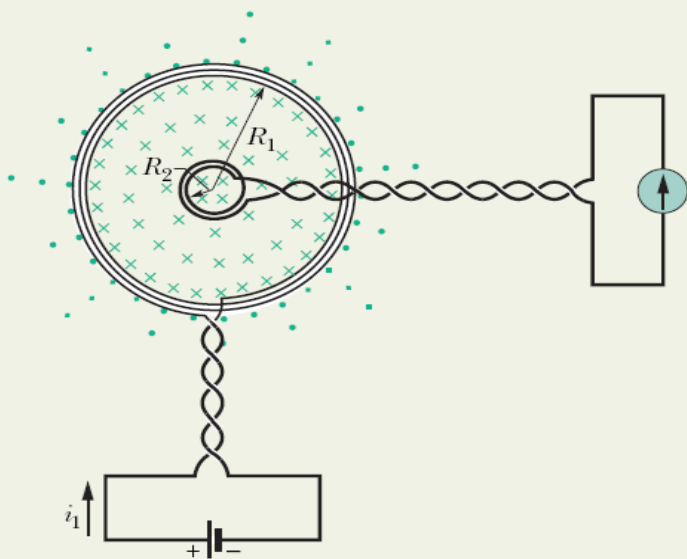

Fig. 30-20 A small coil is located at the center of a large coil. The mutual inductance of the coils can be determined by sending current i_1 through the large coil.

$$M = \frac{N_2 \Phi_{21}}{i_1}. \quad (30-66)$$

The flux Φ_{21} through each turn of the smaller coil is, from Eq. 30-2,

$$\Phi_{21} = B_1 A_2,$$

where B_1 is the magnitude of the magnetic field at points within the small coil due to the larger coil and $A_2 (= \pi R_2^2)$ is the area enclosed by the turn. Thus, the flux linkage in the smaller coil (with its N_2 turns) is

$$N_2 \Phi_{21} = N_2 B_1 A_2. \quad (30-67)$$

To find B_1 at points within the smaller coil, we can use Eq. 29-26,

$$B(z) = \frac{\mu_0 i R^2}{2(R^2 + z^2)^{3/2}},$$

with z set to 0 because the smaller coil is in the plane of the larger coil. That equation tells us that each turn of the larger coil produces a magnetic field of magnitude $\mu_0 i_1 / 2R_1$ at points within the smaller coil. Thus, the larger coil (with its N_1 turns) produces a total magnetic field of magnitude

$$B_1 = N_1 \frac{\mu_0 i_1}{2R_1} \quad (30-68)$$

at points within the smaller coil.

Substituting Eq. 30-68 for B_1 and πR_2^2 for A_2 in Eq. 30-67 yields

$$N_2 \Phi_{21} = \frac{\pi \mu_0 N_1 N_2 R_2^2 i_1}{2R_1}.$$

Substituting this result into Eq. 30-66, we find

$$M = \frac{N_2 \Phi_{21}}{i_1} = \frac{\pi \mu_0 N_1 N_2 R_2^2}{2R_1}. \quad (\text{Answer}) \quad (30-69)$$

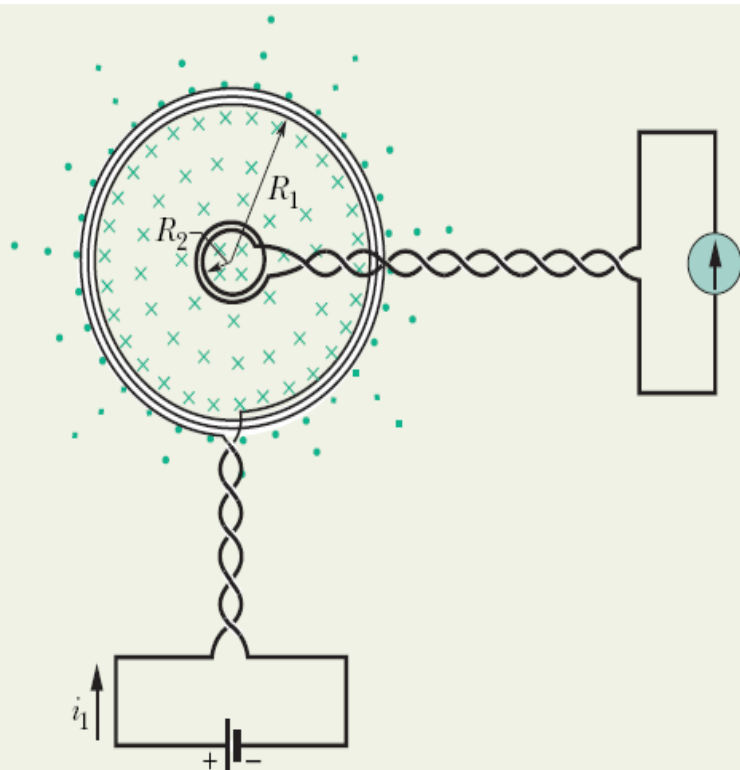

Fig. 30-20 A small coil is located at the center of a large coil. The mutual inductance of the coils can be determined by sending current i_1 through the large coil.

(b) What is the value of M for $N_1 = N_2 = 1200$ turns, $R_2 = 1.1$ cm, and $R_1 = 15$ cm?

Calculations: Equation 30-69 yields

$$M = \frac{(\pi)(4\pi \times 10^{-7} \text{ H/m})(1200)(1200)(0.011 \text{ m})^2}{(2)(0.15 \text{ m})}$$

$$= 2.29 \times 10^{-3} \text{ H} \approx 2.3 \text{ mH.} \quad (\text{Answer})$$

Consider the situation if we reverse the roles of the two coils—that is, if we produce a current i_2 in the smaller coil and try to calculate M from Eq. 30-57 in the form

$$M = \frac{N_1 \Phi_{12}}{i_2}.$$

The calculation of Φ_{12} (the nonuniform flux of the smaller coil's magnetic field encompassed by the larger coil) is not simple. If we were to do the calculation numerically using a computer, we would find M to be 2.3 mH, as above! This emphasizes that Eq. 30-63 ($M_{21} = M_{12} = M$) is not obvious.

Inductor

The inductance L of the inductor is

$$L = \frac{N\Phi_B}{i} \quad \text{Eq. 30-28}$$

The inductance per unit length near the middle of a long solenoid of cross-sectional area A and n turns per unit length is

$$\frac{L}{l} = \mu_0 n^2 A \quad \text{Eq. 30-31}$$

Self-Induction

This self-induced *emf* is,

$$\mathcal{E}_L = -L \frac{di}{dt}$$

Eq. 30-35

Mutual Induction

The mutual induction is described by,

$$\mathcal{E}_2 = -M \frac{di_1}{dt} \quad \text{Eq. 30-64}$$

$$\mathcal{E}_1 = -M \frac{di_2}{dt} \quad \text{Eq. 30-65}$$

Series RL Circuit

Rise of current,

$$i = \frac{\mathcal{E}}{R} (1 - e^{-t/\tau_L}) \quad \text{Eq. 30-41}$$

• Decay of current

$$i = i_0 e^{-t/\tau_L} \quad \text{Eq. 30-45}$$

Magnetic Energy

The inductor's magnetic field stores an energy given by

$$U_B = \frac{1}{2} Li^2 \quad \text{Eq. 30-49}$$

The density of stored magnetic energy,

$$u_B = \frac{B^2}{2\mu_0} \quad \text{Eq. 30-55}$$

5. The current i through a 4.6 H inductor varies with time t as shown by the graph of Fig.30-58, where the vertical axis scale is set by $i_s=8.0$ A and the horizontal axis scale is set by $t_s=6.0$ ms. The inductor has a resistance of 12 Ω . Find the magnitude of the induced emf \mathcal{E} during time intervals (a) 0 to 2 ms, (b) 2 ms to 5 ms, and (c) 5 ms to 6 ms. (Ignore the behavior at the ends of the intervals.)

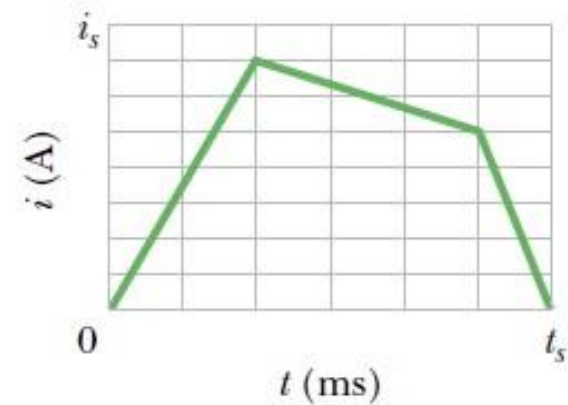

Fig. 30-58 Problem 46.

[a) $\mathcal{E}=1.6 \times 10^4$ V, b) $\mathcal{E}=3.1 \times 10^3$ V, c) $\mathcal{E}= 2.3 \times 10^4$ V]

9 (46)

$L = 4.6$ H
 $i_s = 8.0$ A
 $t_s = 6.0$ ms
 $R_L = 12 \Omega$

i) $\mathcal{E}_L = -L \frac{di}{dt} \rightarrow \mathcal{E} = L \frac{\Delta i}{\Delta t} = 4.6 \text{ H} \frac{(7 \text{ A} - 0)}{2.0 \times 10^{-3} \text{ s}} = 1.6 \times 10^4 \text{ V}$

ii) $\mathcal{E}_L = (4.6 \text{ H}) \frac{(5.0 \text{ A} - 7.0 \text{ A})}{5.0 \times 10^{-3} \text{ s} - 2.0 \times 10^{-3} \text{ s}} = 3.1 \times 10^3 \text{ V}$

iii) $\mathcal{E}_L = (4.6 \text{ H}) \frac{(0 \text{ A} - 5.0 \text{ A})}{6.0 \times 10^{-3} \text{ s} - 5.0 \times 10^{-3} \text{ s}} = 2.3 \times 10^4 \text{ V}$

$|\mathcal{E}| = L \left| \frac{\Delta i}{\Delta t} \right|$
 ignore minus sign